

ZONE 2 FLOODLIGHT

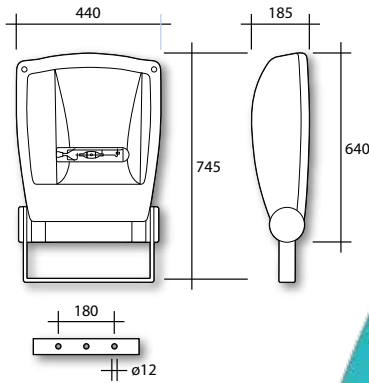

A range of installation columns and brackets are available - Please contact our sales team for further information.

250W-400W S/Q 	1 YEAR* WARRANTY 	IP66 RATING 	OP. TEMP -20°C to +30°C 	VOLTAGE AC220 - 240V
-----------------------------	--------------------------------	---------------------------	---	------------------------------------

- High efficiency Zone 2 and 22, Cat 3 highly durable and versatile luminaire which offers resistance to impact and the adverse effects of moisture, dirt and dust.
- Supplied as standard with timed ignitor to prevent lamp cycling. Suitable for use in gas and dust areas.
- Choice of metal halide or high pressure sodium lamp included.
- Highly durable die cast aluminium body. High purity asymmetric reflector for improved efficiency. Quality sub components used for a long service life. Hinged drop down front for ease of maintenance. Adjustable stirrup with aiming facility for precision mounting. All gaskets are manufactured from heat resistant silicone rubber to ensure IP66 rating.

Code	Description - Including Lamps	Watt
ZFL250S	Zone 2 and Cat 3 floodlight - S lamp SON	250
ZFL400S	Zone 2 and Cat 3 floodlight - S lamp SON	400
ZFL250Q	Zone 2 and Cat 3 floodlight - Q lamp Metal Halide	250
ZFL400Q	Zone 2 and Cat 3 floodlight - Q lamp Metal Halide	400

Certification code: EEx nA II 3 GD
T3 (Tamb -20 to +30 degrees centigrade).
Certificate number: Epsilon 05 ATEX TFZT/01

