

High efficiency energy saving compact fluorescent amenity bulkhead incorporating a 2D lamp, ideally suited to both internal and external applications.

Designed and manufactured to comply with EN 60598 and are CE certified.



WINR



WINS

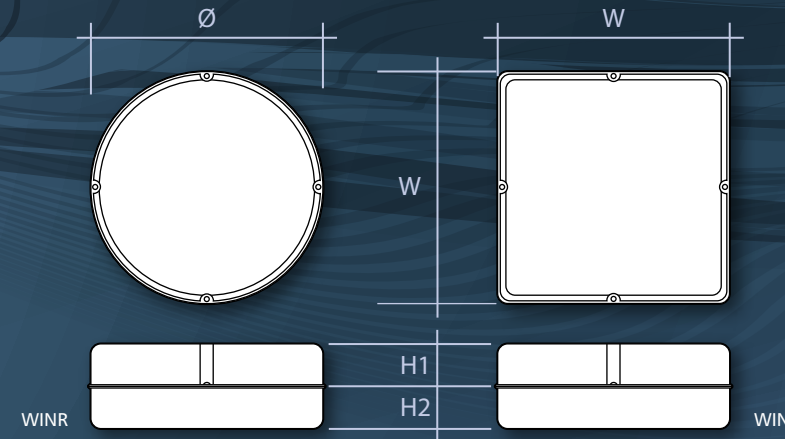

### Lamp Options



2D: 2D Compact Fluorescent

### Product Specification

- Certified ingress protection to IP65
- White body – black available
- A choice of round or square body
- High efficiency energy saving 2D lamp included
- Suitable for wall or ceiling mounting
- Vandal resistant UV stabilised polycarbonate body and prismatic diffuser
- Quality integral control gear for trouble free use
- All gaskets are manufactured from heat resistant silicone rubber to ensure the IP65 rating
- Supplied with high frequency control gear as standard
- For photometry details refer to Page 217 graph ref PC034

### Optional Features

(Add suffix to order code)

**/BL:** Black body (substitute /WH for /BL)

**/FTB:** Fused terminal block

**/TPS:** Tamper proof screws

### Order Codes

Including Lamps

#### WINR - ROUND

Order Code	Watt	Ø	H1	H2	Lamp
WINR16/WH	16	205	38	43	2D
WINR28/WH	28	286	38	43	2D
WINR38/WH	38	360	50	54	2D

#### WINS - SQUARE

Order Code	Watt	W	H1	H2	Lamp
WINS16/WH	16	190	45	45	2D
WINS28/WH	28	260	45	45	2D
WINS38/WH	38	340	50	54	2D

Example order code:

WINS28/WH/HF/E3/TPS – A 28 watt 2D square IP65 fitting with a white body, prismatic diffuser, high frequency control gear, integral 3 hour emergency facility and tamper proof screws. Supplied complete with lamp.



### Applications:

- Internal corridors and access areas
- Store rooms
- Emergency exits
- Under canopy applications
- Wall mounted perimeter lighting
- Wash rooms
- Sports facilities
- Service corridors

### Gear options

- /E3:** 3hr Emergency
- /E3T:** Self Test Emergency