

High power floodlight incorporating either metal halide or high pressure sodium lamp, with power ratings ranging from 600 to 1000 watts. The ignitor is mounted on the stirrup in an IP65 enclosure and the control gear is in a remote IP65 die cast aluminium housing.

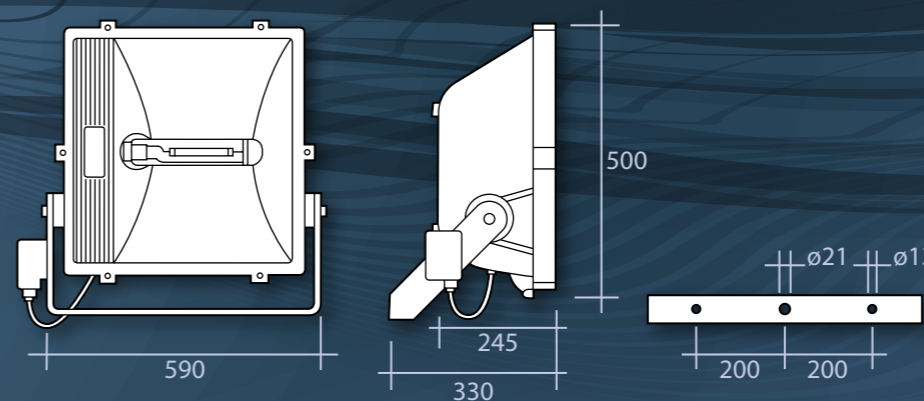

Designed and manufactured to comply with EN 60598 and are CE certified.



### Lamp Options



S: Tubular High Pressure Sodium



Q: Tubular Metal Halide



### Applications:

- Railway marshalling yards
- Large scale external storage areas
- Commercial vehicle parks
- Sports facilities
- Docks
- Building sites

### Product Specification

- Certified ingress protection to IP65
- Supplied as standard with timed ignitor to prevent lamp cycling
- Choice of metal halide or high pressure sodium lamp included
- Highly durable die cast aluminium body
- High purity symmetric reflector for improved efficiency
- Separate IP65 ignitor enclosure for improved reliability
- Remote control gear in an IP65 enclosure can be mounted up to 30 metres from the floodlight
- Quality sub components and porcelain terminal blocks are incorporated for trouble free use
- Wired with high temperature silicone insulated cable for maximum heat resistance
- Hinged drop down front panel for ease of maintenance
- Captive fixings and rugged construction for a long service life
- Heavy duty adjustable stirrup with aiming facility for precision mounting
- All gaskets are manufactured from heat resistant silicone rubber to ensure IP65 rating
- For photometry details refer to Page 215 graph ref PC012
- **Windage guide = 0.245m<sup>2</sup>**

### Optional Features

(Add suffix to order code)

**/AS:** Asymmetric reflector

### IP65 Control Gear Box

Remote mounting cast aluminium IP65 control gearbox.

- Size – 255mm x 185mm x 165mm
- Fixing centres - 230mm x 170mm
- Weight 600 watt - 9.5 Kg's
- Weight 1000 watt - 12.10 Kg's

**For fixing brackets see pages 68-69. For further information on these and for column information please speak to the sales team.**

### Order Codes

Including Lamps

Order Code	Watt	Kg	Lamp
WFL600S	600	12.7	S
WFL1000S	1000	12.7	S
WFL600Q	600	12.7	Q
WFL1000Q	1000	12.7	Q

Example order code:

**WFL1000S** – A 1000 watt high pressure sodium floodlight with an IP65 aluminium body, timed ignitor, remote control gear to IP65 and symmetric reflector. Supplied complete with lamp.