

SOLEX IP65

HEAVY DUTY BULKHEAD

For vandal resistant area lighting

High efficiency rugged bulkhead incorporating either metal halide, high pressure sodium, mercury, or compact fluorescent lamps with power ratings ranging from 26 to 150 watts.

Designed and manufactured to comply with EN 60598 and are CE certified.

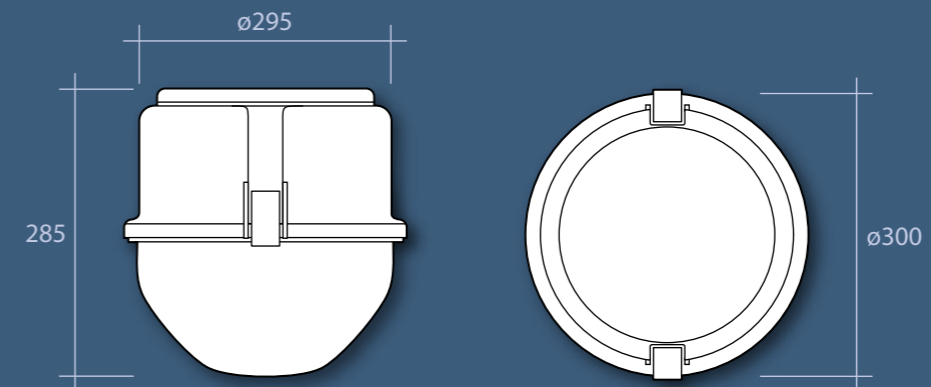

Lamp Options

 S: Tubular High Pressure Sodium

 SI: Elliptical Diffuse High Pressure Sodium with Integral Ignitor

 Q/P: Elliptical Metal Halide – Protected

 M: Elliptical Diffuse Mercury

 TC-D: Compact Fluorescent

Standard Features

- Certified ingress protection to IP65
- Choice of metal halide, high pressure sodium, mercury, or compact fluorescent lamp included
- Detachable fixing plate for speed and ease of installation
- Heavy grade highly durable die cast aluminium body
- Vandal resistant UV stabilised polycarbonate diffuser
- Quality integral control gear for trouble free use
- Easy installation/maintenance with quick release clips and captive diffuser
- All gaskets are manufactured from heat resistant silicone rubber to ensure the IP65 rating

To order Features

(Add suffix to order code)

/TI: Timed ignitor to prevent lamp cycling

/FTB: Fused terminal block

/PEC: Dusk to dawn sensing photo-electric cell

/AST/WBKT: Wall mounting arm (see page 107)

Photometry

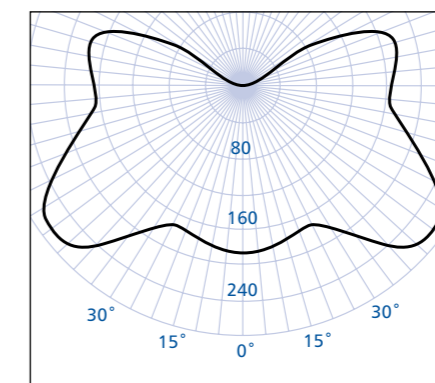

SOL70S

Specification Guide

Order Code	Watt	Kg	Lamp
SOL226TC-D	2 x 26	3.6	TC-D
SOL50S	50	4.5	SI
SOL70S	70	4.5	SI
SOL150S	150	6.0	S
SOL70Q	70	4.5	Q/P
SOL100Q	100	5.9	Q/P
SOL150Q	150	6.2	Q/P
SOL80M	80	5.0	M
SOL125M	125	5.9	M

Example order code:
SOL80M/FTB/PEC – An 80 watt mercury IP65 bulkhead with a fused terminal block, photo-electric cell and lamp.



Applications:

- Car parks
- Railway stations
- Pedestrian tunnels
- Under canopy applications