

High efficiency compact floodlight incorporating either 70 or 150 watt metal halide or high pressure sodium lamps.

Designed and manufactured to comply with EN 60598 and is CE certified.

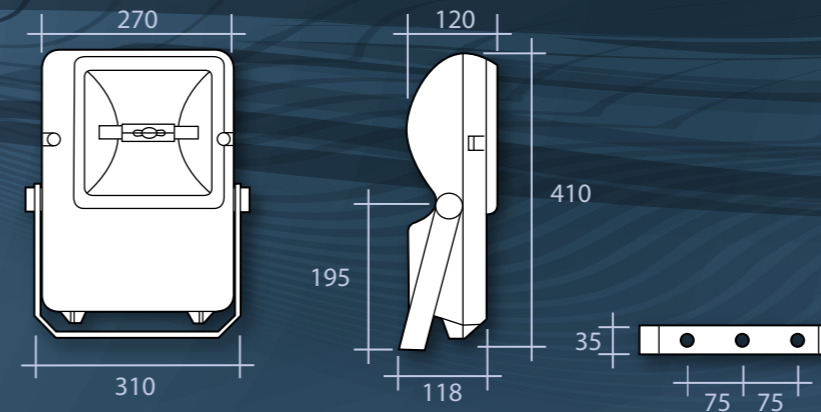

Lamp Options



SI: Elliptical Diffuse High Pressure Sodium with Integral Ignitor



QDE: Linear Metal Halide



Applications:

- Security and general access
- Smaller architectural features
- Amenity lighting
- Roadway lighting
- Feature illumination

Product Specification

- Certified ingress protection to IP65
- Supplied as standard with timed ignitor to prevent lamp cycling
- Choice of metal halide or high pressure sodium lamp included
- Highly durable die cast aluminium body
- Epoxy powder coated black for corrosion resistance
- High purity symmetric reflector for improved efficiency
- Quality integral control gear for trouble free use
- Wired with high temperature silicone insulated cable for maximum heat resistance
- Hinged drop down front panel for ease of maintenance
- Captive fixings and rugged construction for a long service life
- Adjustable stirrup for maximum flexibility in mounting
- All gaskets are manufactured from heat resistant silicone rubber to ensure the IP65 rating
- For photometry details refer to Page 215 graph ref PC011

• **Windage guide = 0.11m²**

Optional Features

(Add suffix to order code)

/FTB: Fused terminal block

/PEC: Dusk to dawn sensing photo-electric cell

Optional Accessories

/WG: Wire guard for improved protection

For fixing brackets see pages 68-69. For further information on these and for column information please speak to the sales team.

Order Codes

Including Lamps

Order Code	Watt	Kg	Lamp
TMP70S	70	5.6	SI
TMP70Q	70	5.5	QDE
TMP150Q	150	6.5	QDE

Example order code:

TMP70S/TI/PEC – A 70 watt high pressure sodium floodlight with an IP65 aluminium body, photo-electric cell and timed ignitor. Supplied complete with lamp.