

SILVER PARK IP66

AMENITY LUMINAIRE

For special application

High performance premium quality amenity luminaire with precision optics, incorporating either a metal halide or high pressure sodium, discharge lamp with power ratings ranging from 70 to 400 watts.

Designed and manufactured to comply with EN 60598 and are CE certified.

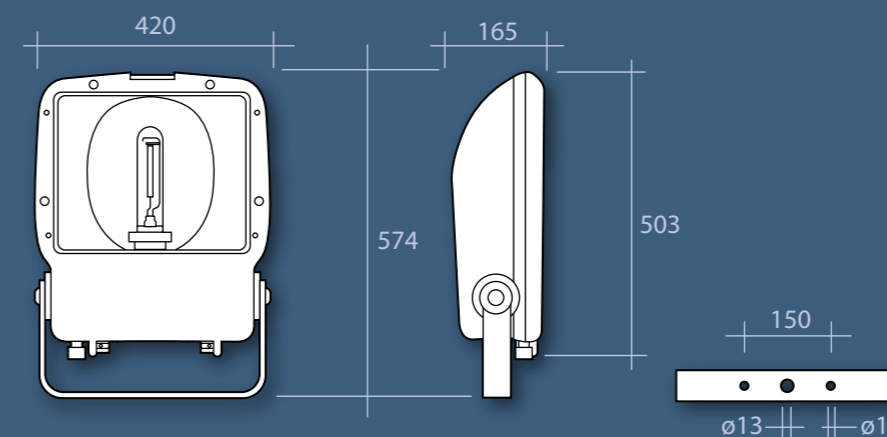

Lamp Options



S: Tubular High Pressure Sodium



Q: Tubular Metal Halide

Standard Features

- Certified ingress protection to IP66
- Batwing reflector and toughened glass front cover
- Choice of metal halide or high pressure sodium lamp included
- Highly durable die cast aluminium body with hinge down frame
- Epoxy powder coated silver for maximum corrosion resistance
- Quality integral control gear for trouble free use
- Easy maintenance with a clip released hinged frame and glass
- Captive fixings and rugged construction for a long service life
- Adjustable stirrup with aiming facility for precision mounting
- All gaskets are manufactured from heat resistant silicone rubber to ensure IP66 rating, supplied with IP66 cable gland
- **Windage guide = 0.09m²**

To Order Features

(Add suffix to order code)

/TI: Timed ignitor to prevent lamp cycling

/FTB: Fused terminal block

/PEC: Dusk to dawn sensing photo-electric cell

For fixing brackets see pages 72/73

Floodlight poles and furniture can be found on pages 108/109

Specification Guide

Order Code	Watt	Kg	Lamp
SPA70S	70	11.4	S
SPA150S	150	12.1	S
SPA250S	250	13.35	S
SPA400S	400	14.45	S
SPA100Q	100	11.5	Q
SPA150Q	150	12.1	Q
SPA250Q	250	13.35	Q
SPA400Q	400	14.45	Q

Example order code:

SPA150Q/TI/PEC – A 150 watt metal halide amenity floodlight with an IP66 die cast aluminium body, glass front, timed ignitor, a photo-electric cell and complete with lamp.

Photometry

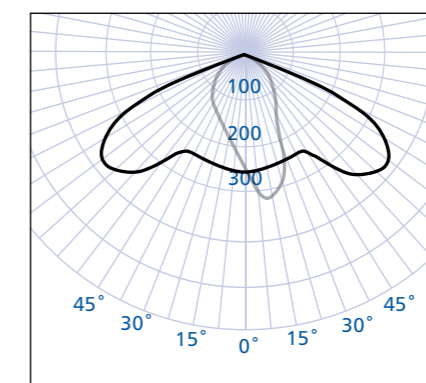

SPA400Q



Applications:

- Car parks
- Environmental floodlighting
- Amenity lighting
- Security lighting
- Railway platform lighting