

Highly durable lightweight rubber bodied task light, which has the benefit of high frequency 110 volt control gear and compact fluorescent lamps, offering high resistance to impact and the adverse affect of moisture, dirt and dust.

Designed and manufactured to comply with EN 60598 and are CE certified.

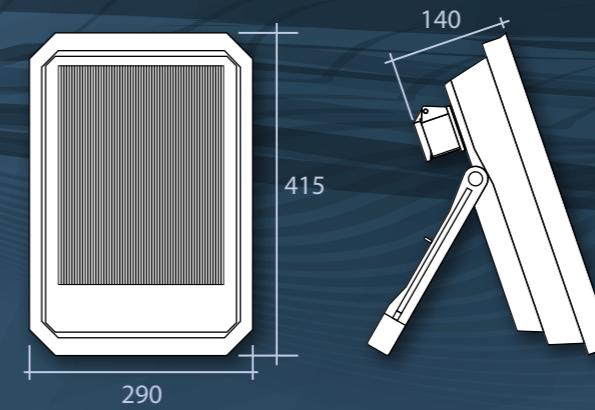

Lamp Options



TC-L: Linear Compact Fluorescent Lamp



CEFL324LV



CEFL324/MV



CEFL324LV



CEFL324/MV



Applications:

- Building sites
- 110 volt working areas
- Industrial task lighting

Ambient temperature guidance

High frequency -25°C - +30°C

Product Specification

- Certified ingress protection to IP54 (sockets IP44)
- 110 volt control gear fitted
- 240 volt option available
- Durable rubber body with UV stabilised impact resistant polycarbonate diffuser
- Supplied with 3 x 24 watt TC-L high efficiency compact fluorescent lamps
- Light weight body incorporates high frequency electronic control gear
- IP44 Accessory sockets fitted: (110 volt three x 16 amp) – (240 volt 2 x 13 amp)
- Pre-wired with 5 metres of cable with the appropriate plug fitted
- Fitted with a retractable locking stand for convenience

Optional Features

(Add suffix to order code)

/MV: 240 volts

Order Codes

Including Lamps

TC-L Lamp

Order Code	Watt	Lamp	Kg
CEFL324LV	3 x 24	TC-L	4.0

Example order code:

CEFL324/MV – A 72 watt 240 volt rubber bodied IP54 floodlight with high frequency control gear, fitted with two IP44 13 amp outlet sockets. Supplied complete with lamps.

High efficiency compact floodlight incorporating either 70 or 150 watt metal halide or high pressure sodium lamps.

Designed and manufactured to comply with EN 60598 and is CE certified.

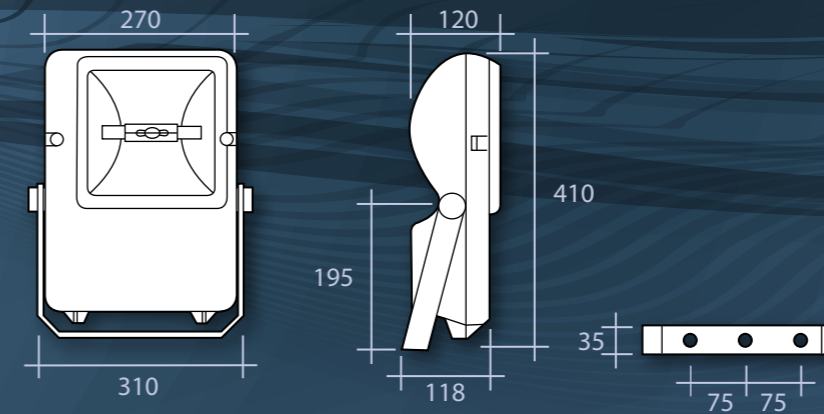

Lamp Options



SI: Elliptical Diffuse High Pressure Sodium with Integral Ignitor



QDE: Linear Metal Halide

Product Specification

- Certified ingress protection to IP65
- Choice of metal halide or high pressure sodium lamp included
- Highly durable die cast aluminium body
- Epoxy powder coated black for corrosion resistance
- High purity symmetric reflector for improved efficiency
- Quality integral 110V control gear for trouble free use
- Wired with high temperature silicone insulated cable for maximum heat resistance
- Hinged drop down front panel for ease of maintenance
- Captive fixings and rugged construction for a long service life
- Adjustable stirrup for maximum flexibility in mounting
- All gaskets are manufactured from heat resistant silicone rubber to ensure the IP65 rating
- **Windage guide = 0.11m²**

Optional Features

(Add suffix to order code)

/FTB: Fused terminal block

/PEC: Dusk to dawn sensing photo-electric cell (not available on TMP70S/LV)

Optional Accessories

/WG: Wire guard for improved protection

For fixing brackets see pages 68-69. For further information on these and for column information please speak to the sales team.

Order Codes

Including Lamps

Order Code	Watt	Kg	Lamp
TMP70S/LV	70	7.6	SI
TMP150Q/HF/LV	150	8.0	QDE

Example order code:

TMP70S/LV – A 70 watt high pressure sodium floodlight with an IP65 aluminium body. Supplied complete with lamp.



Applications:

- Security and general access
- Smaller architectural features
- Amenity lighting
- Roadway lighting
- Feature illumination
- Temporary site lighting

Solent IP65 230V also available - see page 42-43