

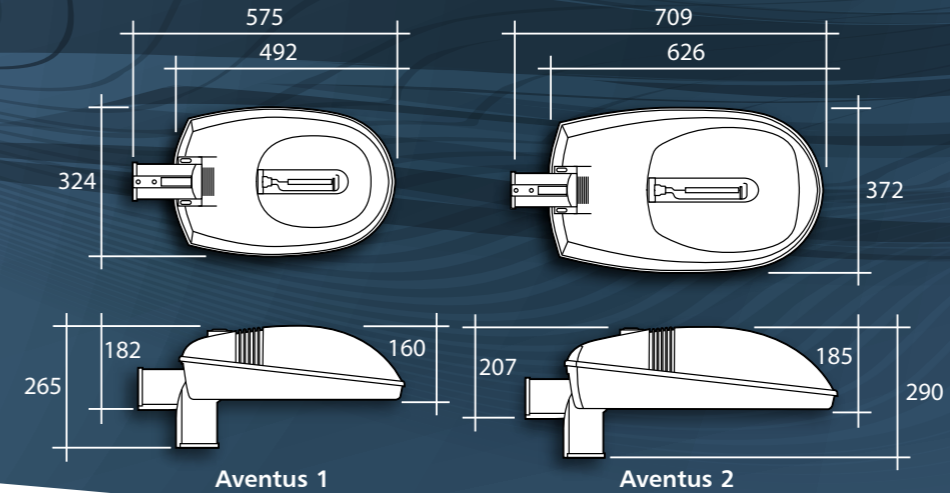

Precision engineered, IP66 street lighting lanterns, incorporating either metal halide or high-pressure sodium lamps with power ratings of 70 watt to 400 watts. For ultimate optical control the product is designed with 'cutoff' or 'semi cut-off' optics.

Designed and manufactured to comply with EN 60598-1 and are CE certified.



Lamp Options



S: Tubular High Pressure Sodium



Q: Tubular Metal Halide



Applications:

- Pathway lighting
- Roadway lighting
- Car parks
- Security
- Amenity

Hot dipped galvanised Parallel Sided Poles with access door

Order Code	Root Mnt	Flange Mnt	H (m)	L (m)	PD (m)	Kg
COL4RM76	COL4FM76		4	4.8	0.8	30
COL5RM76	COL5FM76		5	5.5	0.8	37
COL6RM76	COL6FM76		6	6.7	1.0	45

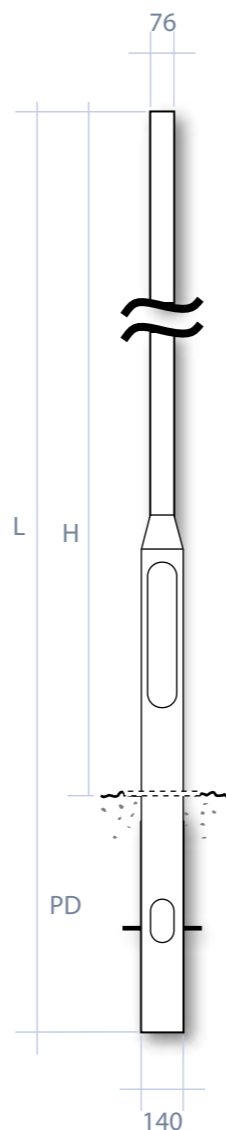

Product Specification

- Certified ingress protection to IP66
- Choice of two body sizes:
Aventus 1 – 70/100/150 watt
Aventus 2 – 250/400 watt
- Choice of two optics:
Flat toughened glass – cut-off (fitted)
Curved toughened glass – semi cut-off
- Adjustable mounting bracket for base or side entry
- All available with NEMA socket for use with a photocell
- One piece high performance anodised aluminium reflector for improved light distribution
- Heavy grade die cast aluminium body finished in grey thermset polyester powder coating for improved corrosion resistance
- Timed ignitor to prevent lamp cycling
- Quality integral control gear for a long service life
- Supply cut off switch operates when the gear box is opened for added safety
- Quick release top cover for ease of maintenance
- **Windage guide:**
Aventus 1 - 0.09m²
Aventus 2 - 0.13m²

Optional Features

(Add suffix to order code)

/NEMA: Dusk to dawn sensing photo electric cell

/FTB: Fused terminal block

/SCOG: Curved toughened front glass - semi cut-off

Note Astra spigot required if post top mounting - Order Code ASTRASPIG76F/60M.

Order Codes

Including Lamps

Aventus 1

Order Code	Watt	Kg	Lamp
AVT1/70S	70	7.9	S
AVT1/150S	150	8.7	S
AVT1/70Q	70	8.1	Q
AVT1/100Q	100	8.7	Q
AVT1/150Q	150	8.8	Q

Special Note: Using /SCOG increases luminaire height by 40mm.

Aventus 2

Order Code	Watt	Kg	Lamp
AVT2/250S	250	12.7	S
AVT2/400S	400	13.9	S
AVT2/250Q	250	10.8	Q
AVT2/400Q	400	13.8	Q

Special Note: Using /SCOG increases luminaire height by 55mm.

Example order code:

AVT2/250Q/TI/SCOG/NEMA – A 250 watt metal halide Aventus 2 lantern fitted with a timed ignitor, semi cut-off curved glass and NEMA photo electric cell. Supplied complete with lamp.

Also available with LED's, Motion and Daylight sensors - see page 200-201