

ZEXEN FL ZONE 2 IP66

ZONE 2 FLOODLIGHT

For hazardous area lighting

High efficiency Cat 3 (Zone 2 and 22) highly durable and versatile luminaire which offer resistance to impact and the adverse effects of moisture, dirt and dust.

Designed and manufactured to comply with EN 50021 and is CE certified.

Certification code: EEx nA II 3 GD
T3 (Tamb -20 to +30 degrees centigrade).
Certificate number: Epsilon 05 ATEX TFZT/01

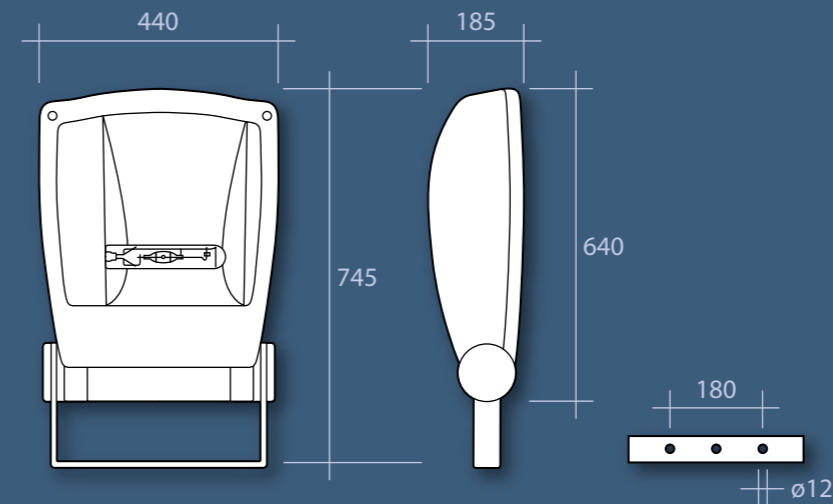

Lamp Options



S: Tubular High Pressure Sodium



Q: Tubular Metal Halide

Standard Features

- Certified ingress protection to IP66
- Suitable for use in gas and dust areas
- Choice of metal halide or high pressure sodium lamp included
- Highly durable die cast aluminium body
- High purity asymmetric reflector for improved efficiency
- Quality sub components used for a long service life
- Hinged drop down front for ease of maintenance
- Adjustable stirrup with aiming facility for precision mounting
- All gaskets are manufactured from heat resistant silicone rubber to ensure IP66 rating
- **Windage guide = 0.28m²**

For fixing brackets see pages 72/73

Floodlight poles and furniture can be found on pages 108/109

Specification Guide

| Order Code | Watt | Kg | Lamp |
|------------|------|----|------|
| ZFL250S | 250 | 22 | S |
| ZFL400S | 400 | 22 | S |
| ZFL250Q | 250 | 22 | Q |
| ZFL400Q | 400 | 22 | Q |

Example order code:
ZFL250S – A 250 watt high pressure sodium floodlight with an IP66 aluminium body complete with lamp.

Photometry

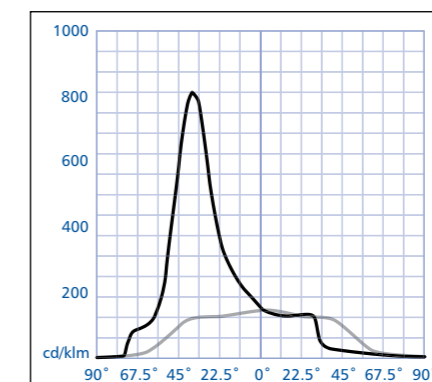

ZFL400S



Applications:

- Flour mills
- Cat 3 Zone 2 nominated hazardous areas
- Grain stores
- Dusty environments