

ZEXEN CR ZONE 2 IP65

ZONE 2 CORROSION RESISTANT FLUORESCENT LUMINAIRES

For hazardous area lighting



High efficiency Cat 3 (Zone 2 and 22) highly durable and versatile luminaires which offer resistance to impact and the adverse effects of moisture, dirt and dust.

Designed and manufactured to comply with EN 50021 and are CE certified.

Certification code: EEx n c II 3 GD

T4 (Tamb -40 to +55 degrees centigrade). Certificate number:

Epsilon EX02ATEX1167.



Applications:

- Flour Mills
- Grain Stores
- Dusty Environments
- Cat 3 Zone 2 nominated hazardous areas

Ambient temperature guidance

High frequency -25°C - +30°C
Integral emergency 0°C - +25°C

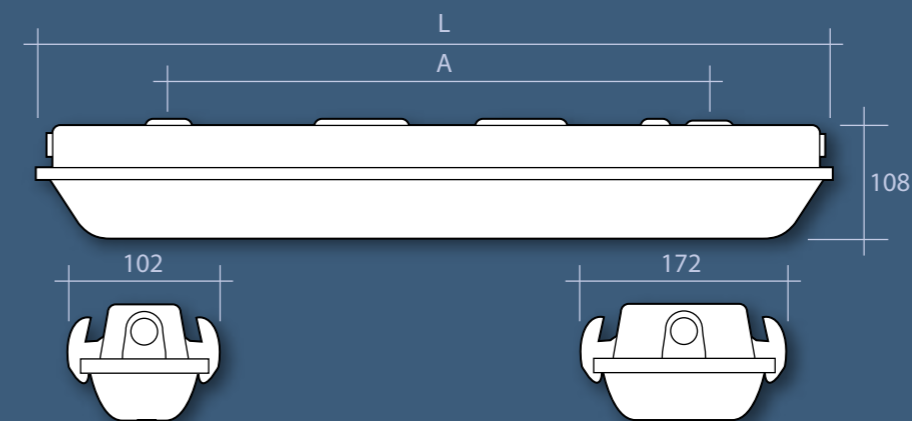

Lamp Options

 T8: 26mm Fluorescent Tubes

Standard Features

- Certified ingress protection to IP65
- Suitable for gas and dust areas
- Unrestricted breathing enclosure, no need for annual gasket inspection or pressure testing
- Stainless steel diffuser retention clips
- Fire retardant UV stabilised impact resistant injection moulded polycarbonate diffuser
- Glass fibre re-enforced polyester body for maximum durability
- Diffuser retention clips can be locked for improved vandal resistance
- Quality high frequency control gear and sub components for maximum service life
- Modern tooling ensures precision mouldings for a perfect fit every time
- Poured neoprene closed cell anti-ageing gasket for a perfect seal

To Order Features

(Add suffix to order code)

/E3INT: Integral maintained three hour emergency

/WBCR-HANGERC1: Stainless steel mounting clips for single body

/WBCR-HANGERC2: Stainless steel mounting clips for twin body

For Accessories please see pages 30/31

Specification Guide

T8 Tube

Order Code	Watt	L	A	Clips	Kg
ZEX136/HF	1 x 36	1312	800	8	3.0
ZEX158/HF	1 x 58	1612	1100	10	4.0
ZEX218/HF	2 x 18	702	500	4	4.5
ZEX236/HF	2 x 36	1312	800	8	4.5
ZEX258/HF	2 x 58	1612	1100	10	5

Example order code:

ZEX258/HF/E3INT – A 2 x 58 watt T8 corrosion resistant IP65 ZONE 2 fluorescent luminaire with high frequency control gear, polycarbonate diffuser, integral emergency facility and stainless steel vandal resistant diffuser retention clips. Supplied without lamp.

Photometry

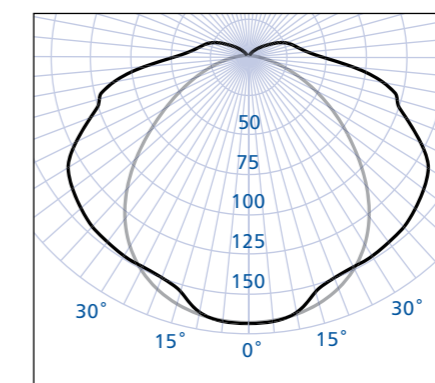

ZEX218/HF