

ZEXEN BH ZONE 2 IP65

BULKHEAD

For hazardous area lighting

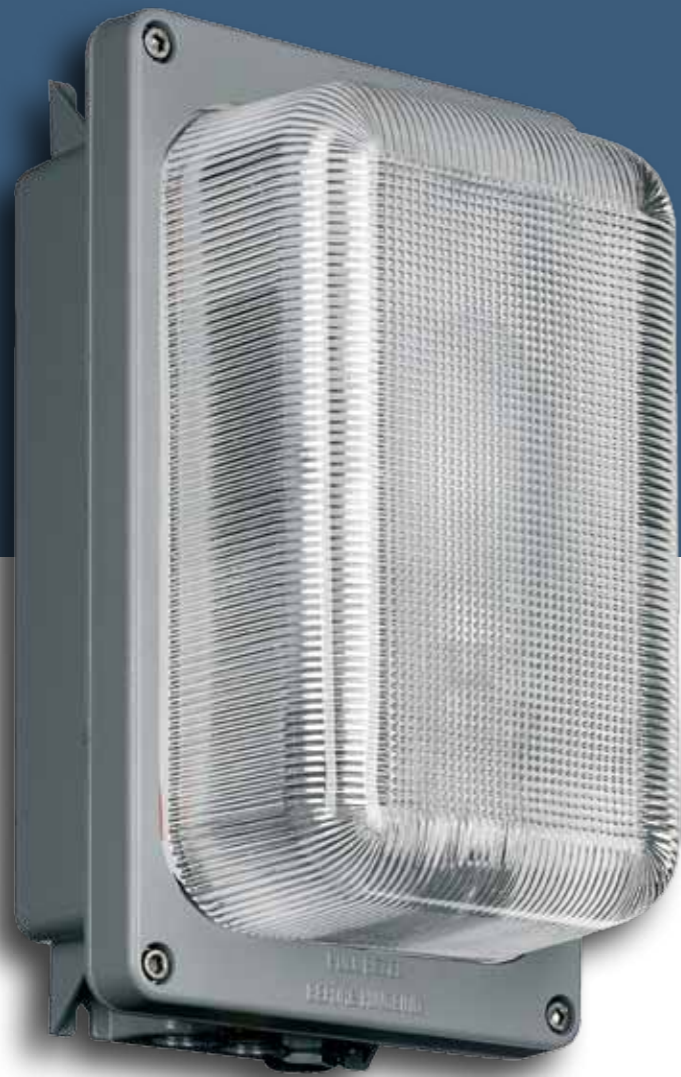

High efficiency wall mounted cast aluminium luminaire incorporating either 70 watt metal halide or, 70 watt high pressure sodium discharge lamp.

Designed and manufactured to comply with EN 50021 and are CE certified.

Certification code: EEx nC II 3 GD

T3 (Tamb -20 to + 30)

Certificate number 03 ATEX TFDN/01
(Restricted breathing).

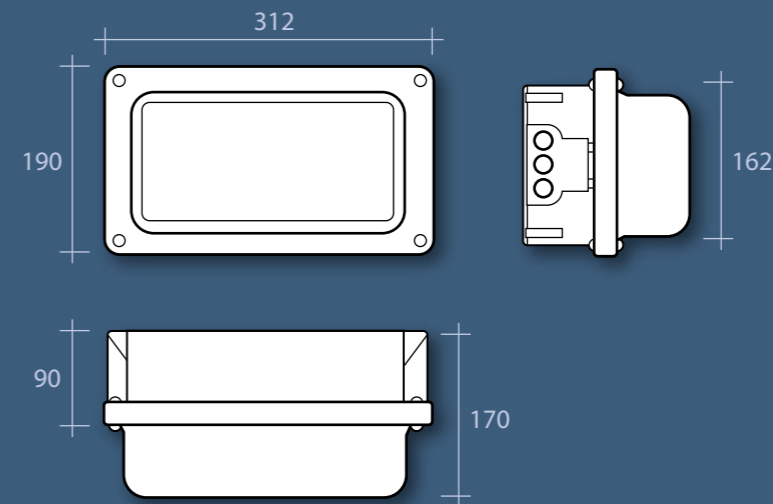

Lamp Options



S: Tubular High Pressure Sodium



Q: Tubular Metal Halide

Standard Features

- Certified ingress protection to IP65
- Choice of metal halide or high pressure sodium lamp included
- Suitable for gas and dust areas with restricted access
- Highly durable heavy die cast aluminium body and optic frame
- Quality sub components used for a long service life
- Easy installation with two M20 ISO cable entries and large terminal block
- All gaskets are manufactured from heat resistant silicone rubber to ensure IP65-rating

Specification Guide

Order Code	Watt	Kg	Lamp
ZBH70S	70	6	S
ZBH70Q	70	6	Q

Example order code:
ZBH70S – A 70 watt high pressure sodium IP65 Zone 2 bulkhead with lamp.



Applications:

- Cat 3 Zone 2 nominated hazardous areas
- Flour mills
- Grain stores
- Dusty environments

Photometry

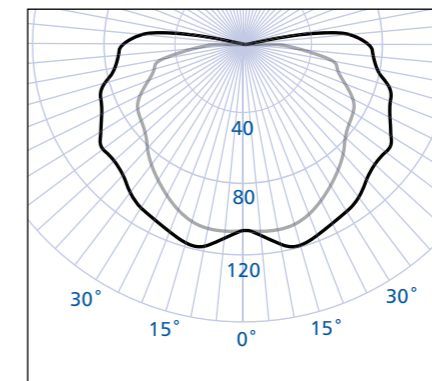

ZBH70S