

ROMSEY REFLECTOR IP20

HIGH BAY

For general industrial and commercial application



High efficiency high bay luminaire incorporating either metal halide, high pressure sodium, or mercury discharge lamp with power ratings ranging from 150 to 400 watts. A wide range of accessories are available to offer solutions for demanding applications.

Designed and manufactured to comply with EN 60598 and are CE certified.

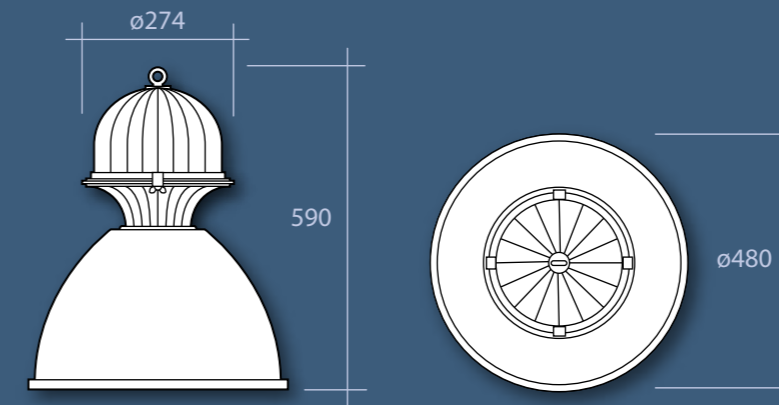

Lamp Options



S: Tubular High Pressure Sodium



Q: Tubular Metal Halide



M: Elliptical Diffuse Mercury



Applications:

- Warehousing
- Manufacturing plants
- Aircraft hangers
- Internal sports facilities
- Retail super stores and precincts

Standard Features

- Certified ingress protection to IP20
- Choice of metal halide, high pressure sodium, or mercury lamp included
- Corrosion resistant epoxy powder coated aluminium body
- Gear tray easily removed for trouble free installation and c/w wiring gland
- Quality sub components for extended service life
- Wired with high temperature silicone insulated cable for maximum heat resistance
- High purity machine spun aluminium reflector for maximum efficiency
- Metal halide versions supplied with toughened front glass for added safety
- Can be used with Sylvania twin arc high pressure sodium lamps for extended life

To order Features

(Add suffix to order code)

/TI: Timed ignitor to prevent lamp cycling

/FTB: Fused terminal block

Accessories

/GLASS: Front cover

For Accessories please see page 95

Photometry

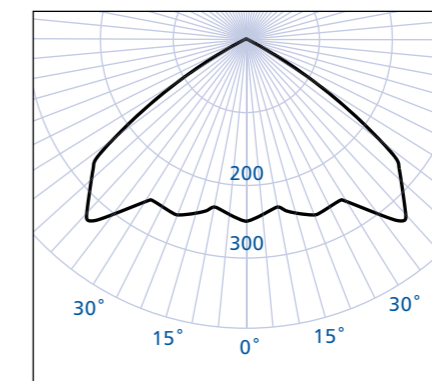

CHB400Q

Specification Guide

Order Code	Watt	Kg	Lamp
CHB150S	150	6.5	S
CHB250S	250	8.2	S
CHB400S	400	9.3	S
CHB250Q	250	9.1	Q
CHB400Q	400	10.2	Q
CHB250M	250	6.8	M
CHB400M	400	8.8	M

Example order code:
CHB250M/FTB - A 250 watt mercury high bay luminaire with an aluminium reflector, fitted with a fused terminal block and supplied c/w lamp.