

ROMA IP65

PROFESSIONAL POLYCARBONATE FLOODLIGHT

For general area lighting

High efficiency floodlight with UV stabilised impact resistant polycarbonate body incorporating metal halide, high pressure sodium, or mercury discharge lamp with power ratings ranging from 150 to 400 watts.

Designed and manufactured to comply with EN 60598 and are CE certified.

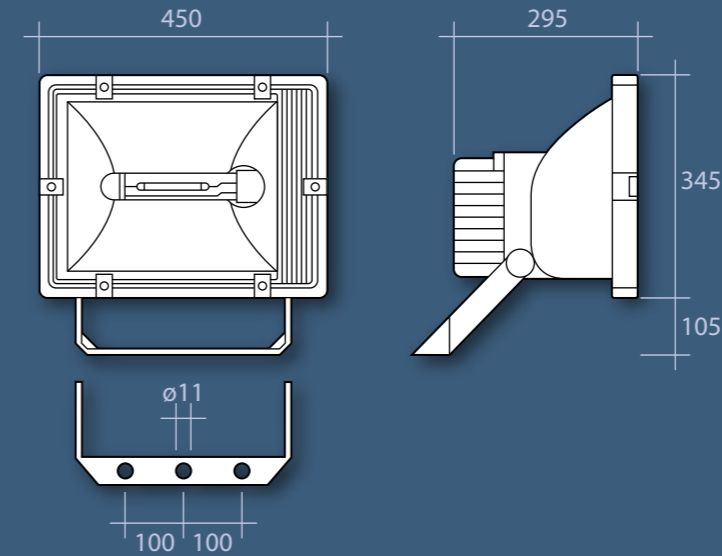

Lamp Options



S: Tubular High Pressure Sodium



Q: Tubular Metal Halide



M: Elliptical Diffuse Mercury



Q/P: Elliptical Metal Halide - Protected

Standard Features

- Certified ingress protection to IP65
- Choice of metal halide, high pressure sodium or mercury lamp included
- Highly durable UV stabilised impact resistant polycarbonate body
- Improved resistance to salt water corrosion
- High purity symmetric reflector for improved efficiency, with an asymmetric reflector option
- Quality integral control gear for trouble free use
- Wired with high temperature silicone insulated cable for maximum heat resistance
- Easy maintenance with quick release toughened front glass
- Captive fixings and rugged construction for a long service life
- Adjustable stirrup with aiming facility for precision mounting
- All gaskets manufactured from heat resistant silicone rubber to ensure IP65 rating
- **Windage guide = 0.15m²**

To Order Features

(Add suffix to order code)

/TI: Timed ignitor to prevent lamp cycling

/FTB: Fused terminal block

/PEC: Dusk to dawn sensing photo-electric cell

/TPS: Power switching

/AS: Asymmetric reflector (sodium and metal halide only)

/WH: White housing

Accessories

/WG: Wire guard for improved protection

For fixing brackets see pages 72/73

Floodlight poles and furniture can be found on pages 108/109

Photometry

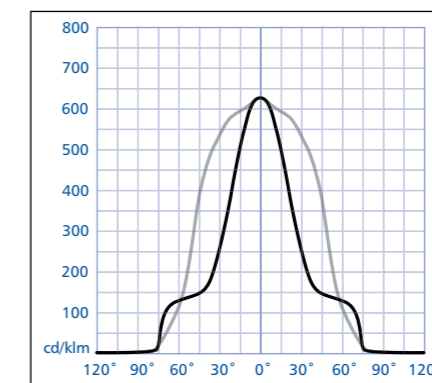

WFL400S/POLY

Specification Guide

Order Code	Watt	Kg	Lamp
WFL150S/POLY	150	7.2	S
WFL250S/POLY	250	8.5	S
WFL400S/POLY	400	10.6	S
WFL150Q/POLY	150	7.4	Q/P
WFL250Q/POLY	250	8.1	Q
WFL400Q/POLY	400	8.4	Q
WFL250M/POLY	250	7.8	M
WFL400M/POLY	400	8.2	M

Example order code:

WFL400Q/POLY/TI/PEC - A 400 watt metal halide floodlight with an IP65 polycarbonate body, timed ignitor, photo-electric cell and complete with lamp.



Applications:

- Marine floodlighting
- Security and general access
- Architectural features
- Sports facilities
- Car parks