

Adopt the latest LED semiconductor technology, high optical efficiency and maximum light output. Saves over 60% of energy compared with the traditional light.

An ideal green and energy-saving lamp.

Solid state light source, no ultraviolet, no infrared radiation, flicker-free. Environmentally friendly, mercury-free, lead free and RoHS compliant.

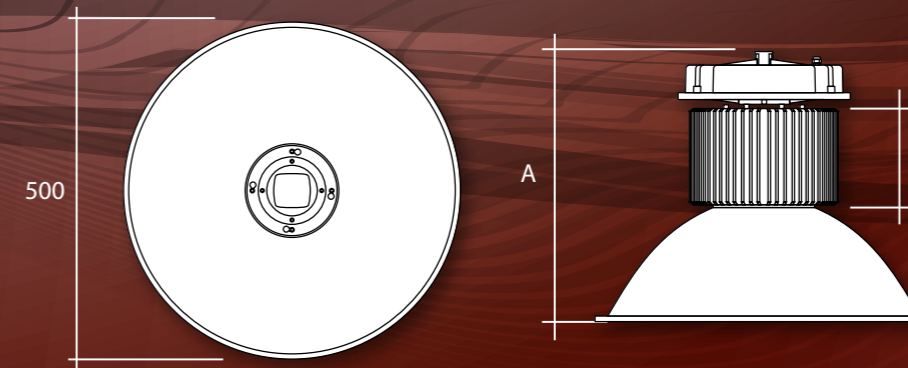

Lamp Options



LED: Light Emitting Diode

Product Specification

- Certified ingress protection to IP65
- Instant on/off operation
- Universal input (100-277 VAC), 50/60Hz
- Superior colour rendition index compared to HPS, LPS & MV
- Mercury free
- Resistant to shock and vibration
- Temperature compensation technology for longer life
- >80% lumen maintenance after 50,000 operating hours
- Copper free aluminium

Order Codes

Including Lamps

Order Code	Watt	A	B	Kg	Lamp
LHB147	147	470	155	8.0	LED
LHB300	300	570	255	10.0	LED

Example order code:

LHB147 - A 147 watt LED High Bay luminaire.



Applications:

- Warehouses
- Garage Lighting
- Cold Stores
- Tunnel and general area lighting

Intelligent Options

Our technical team can help you to design a practical solution for your specific needs. Please contact us so that we can assist you to consider the best options from our full range of lighting controls.

