

# GARDA IP65

COMPACT POLYCARBONATE FLOODLIGHT

For general area lighting

High efficiency cost effective floodlight incorporating a 70 watt high pressure sodium lamp.

Designed and manufactured to comply with EN 60598 and is CE certified.

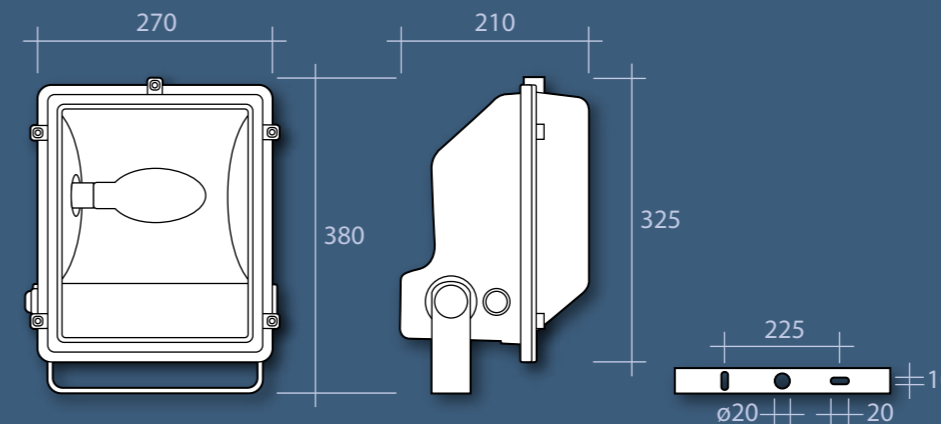

## Lamp Options



SI: Elliptical Diffuse High Pressure Sodium with Integral Ignitor

## Standard Features

- Certified to ingress protection to IP65
- High pressure sodium lamp with internal ignitor included
- UV stabilized impact resistant polycarbonate body and diffuser
- Symmetric reflector
- Integral control gear
- Easy installation with a clear drop down front cover and IP65 cable gland
- Adjustable stirrup for easy mounting
- All gaskets manufactured from heat resistant silicone rubber to ensure IP65 rating
- **Windage guide = 0.11m<sup>2</sup>**

## Specification Guide

Order Code	Watt	Kg	Lamp
CE70S-POLY	70	3.3	SI

Example order code:

CE70S – A 70 watt high pressure sodium floodlight with a polycarbonate IP65 body and diffuser complete with lamp.



## Applications:

- Security
- General exterior lighting
- Amenity lighting