

CHANDLER IP65

TEMPORARY SITE LIGHTING

For low voltage construction site application

Highly durable polycarbonate fluorescent luminaires which offer high resistance to impact and the adverse effect of moisture, dirt and dust.

Designed and manufactured to comply with EN 60598 and are CE certified.



Applications:

- Building sites
- 110 volt working areas
- Industrial task lighting

Ambient temperature guidance

Switch start 0°C - +30°C
Integral emergency 0°C - +25°C

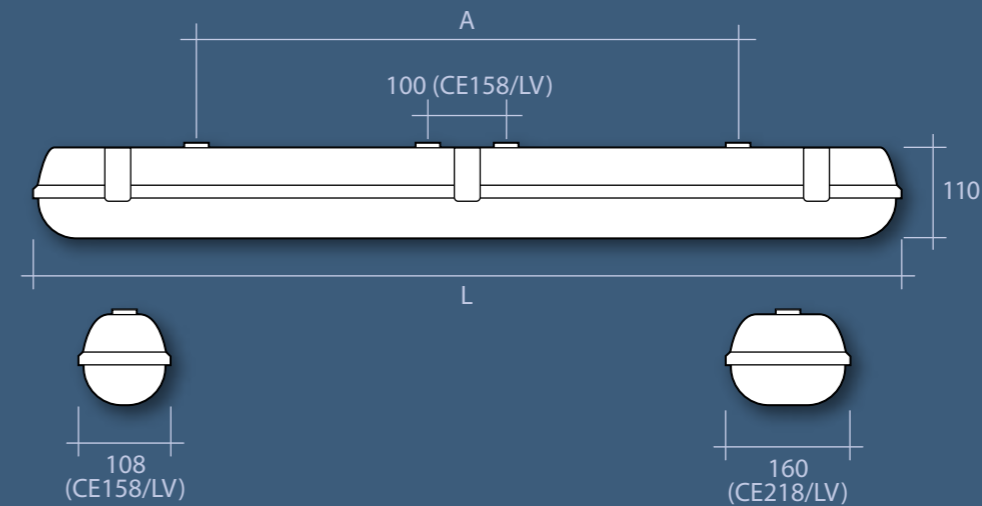

Lamp Options

T8: 26mm Fluorescent Tubes

Standard Features

- Certified ingress protection to IP65
- Warranted for use at one site only
- UV stabilised impact resistant polycarbonate body and diffuser
- Diffuser retention clips captive to the body for ease of installation
- Fixing kit includes wiring gland and metal quick fix mounting plates and hooks
- Poured gasket for a perfect seal
- Powder coated gear trays ensure no sharp edges
- 110 volt switch start control gear as standard
- Power factor correction capacitor fitted

To order Features:

(Add suffix to order code)

/E3INT: Integral maintained three hour emergency

For Accessories please see pages 30/31

Specification Guide

T8 Tube

Order Code	Watt	L	A	Clips	Kg
CE158/LV	1 x 58	1570	1280	12	3.6
CE218/LV	2 x 18	660	530	6	1.9

Example order code:

CE158/LV- A 1 x 58 watt T8 110 volt corrosion resistant IP65 fluorescent luminaire with switch start control gear, polycarbonate body and diffuser, and fixing kit. Supplied without lamp.

Photometry

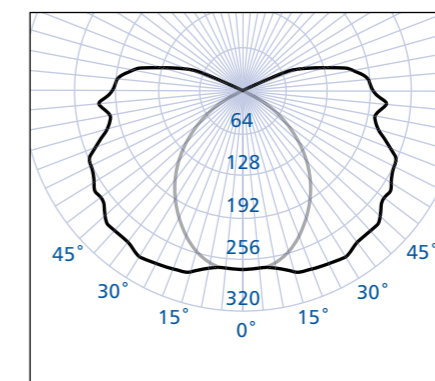

CE158/LV